



FLOW PASSAGE OPTIONS

4

6



What is a Rotary Union?

Overview

How To Order

Specifications & Operating Information

HVH 4 Passage Dimensions

HVH 6 Passage Dimensions

Electrical Slip Ring Integration Options

Capsule Slip Ring Protective Cap Dimensions

Through Bore Slip Ring Dimensions

Installation & Mounting

Warranty

Dynamic Sealing Technologies, Inc. (DSTI) serves a wide range of global industries as a leader in engineered fluid sealing and transfer solutions for rotating applications.

DSTI core business segments are fluid rotary unions, electrical slip rings, and value-added products and services—providing customers with a single-source solution from design and manufacturing through to testing and qualification—all under one roof. Located in North America and Europe with a team of distribution partners and technical support specialists worldwide.

Learn more at



DID YOU KNOW?

DSTI Exports Products to
Over 60 Countries.



A rotary union (or swivel joint) is a mechanism used to transfer fluid (under pressure or vacuum) from a stationary inlet to a rotating outlet, preserving and isolating the fluid connection.

Rotary unions are engineered to endure a wide range of temperatures and pressures for a variety of conditions and environments. In addition, rotary unions may integrate multiple passages and handle different types of fluid simultaneously.

See examples at

HOW DO I CHOOSE THE BEST ROTARY UNION FOR MY APPLICATION?

Tell us about your requirements so we can make a recommendation:

- Type of media(s) / fluid(s) to be transferred
- Number of independent flow channels (passages)
- Operating pressure
- Operating temperature
- Operating speed
- Shaft & housing connection type
- Flow channel (passage) size
- Torque & load requirements
- Duty cycle

Does the temperature, speed or pressure fluctuate or change during operation? If so, please provide the detailed ranges for each parameter and time durations of each condition.

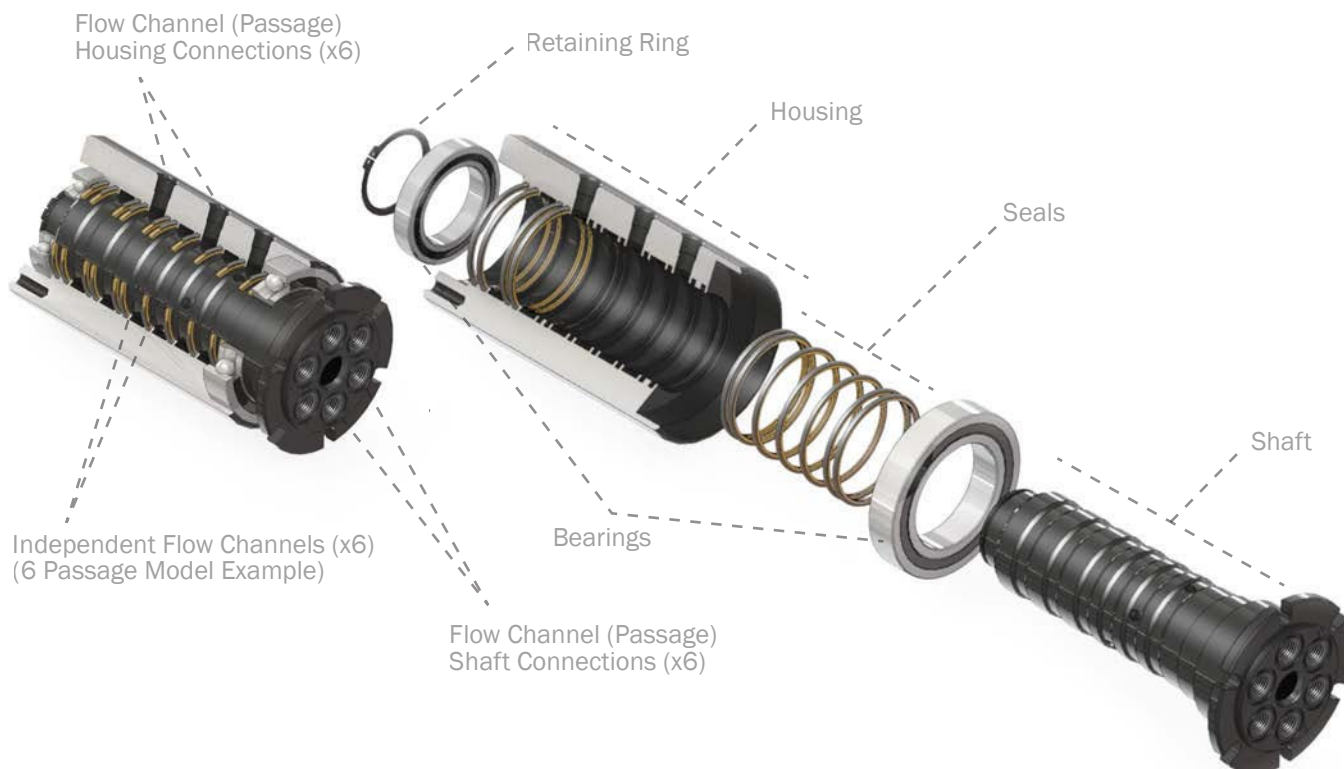



Suitable For Vacuum & Bidirectional Pressures
Up To 5,000 PSI

Large Flow Passages & Increased Flow Volume

Heavy-Duty Alloy Steel/Ductile Iron Construction

Corrosion Resistant Black Oxide Surface Treatment

Electrical Slip Ring Options Available

Aluminum Slip Ring Cover Option To Protect
Capsule Slip Ring In Harsh Environments

Nylon Cord Grip Standard When Using Slip Rings



The HVH Series multiple-passage rotary unions are available in 4 and 6 flow passages. Designed for applications requiring high flow volume at low rotational speeds, the HVH Series has large diameter flow passages suitable for vacuum & bidirectional pressures up to 5,000 PSI [345 BAR].

Its heavy-duty construction features an alloy steel shaft and ductile iron housing with a black oxide coating for mild corrosion resistance, making the HVH Series an ideal solution for tough, outdoor environments.

All models come standard with female tapped SAE-ORB connections on the face of the shaft and the side of the housing. To mount the HVH Series we have included tapped holes on the ends of the shaft and housing.



PRODUCT DOWNLOADS

For Catalogs, Brochures, Models and Drawings visit



Create your Part Number

3

0

0

1

Thru-bore

See Next Page

All HVH Series rotary unions include an open bore to allow electrical wires to pass through it.

4 Flow Passages

6 Flow Passages

#8 SAE-ORB (3/4"-16 UNF) Connections
0.44" (11.1mm) Flow Passages

#16 SAE-ORB (1-5/16"-12 UN) Connections
0.88" (22.2mm) Flow Passages

Product Series

HVH-304041

4-Passage with #8 SAE-ORB (3/4"-16 UNF) Connections

HVH-306041

4-Passage with #16 SAE-ORB (1-5/16"-12 UN) Connections

HVH-304061

6-Passage with #8 SAE-ORB (3/4"-16 UNF) Connections

HVH-306061

6-Passage with #16 SAE-ORB (1-5/16"-12 UN) Connections





Choose your Options

HVH 3 0 4 0 4 1

	6 - 56 Circuits 240 Volts
	8 - 51 Circuits 240 Volts Ethernet
ESMx	9 - 52 Circuits 240 Volts
ESTx	6 - 24 Circuits 600 Volts
ESETx	4 - 22 Circuits 240, 600 Volts Ethernet

See Electrical Slip Ring Options on page 10 for full specs
 600V max on 16 AWG power circuits, 240v maximum on Ethernet cable.

Optional Cap For Capsule Slip Rings (ES, ESE and ESM)

+

HVH-304041-ESE2124-C
 HVH 4-Passage model with thru-bore, #8 SAE-ORB connections and an ESE2124 ethernet slip ring plus optional protective aluminum cap

Labels in diagram: C, ESE2124, HVH-304041

+

HVH-306061-ESET184
 HVH 6-Passage with thru-bore, #16 SAE-ORB connections and an ESET184 thru-bore ethernet slip ring plus required adapter

Labels in diagram: ESET184, ADAPTER, HVH-306061

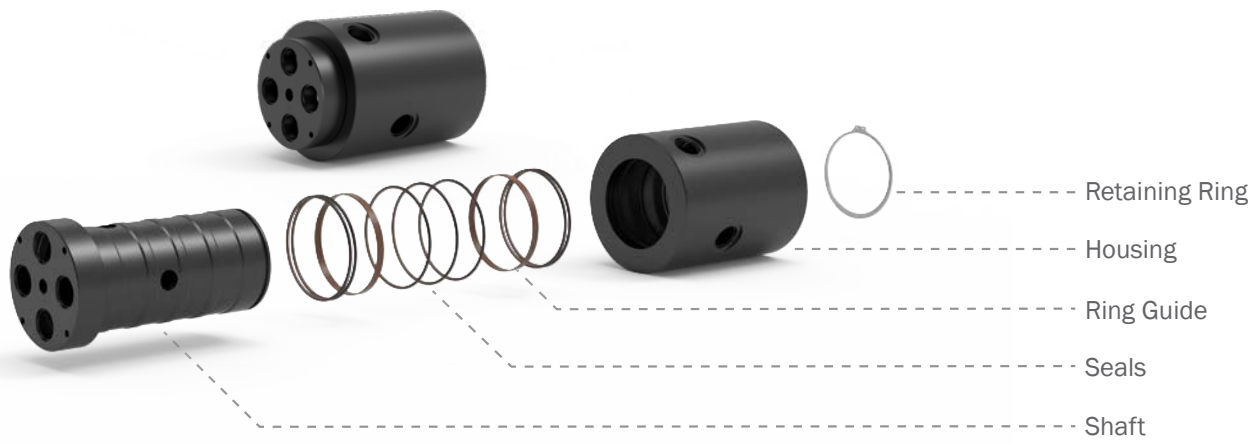

Media Types	Air/Gas, Oil/Hydraulic	
Connection Size	#8 SAE-ORB (3/4"-16 UNF), #16 SAE-ORB (1-5/16"-12 UN)	
Passage Size	0.44" (11.1mm), 0.88" (22.2mm)	
Max. Operating Pressure	5,000 PSI (345 BAR) ¹	
Max. Vacuum	30 HG	
Max. Rotational Speed	20 RPM ¹	
Operating Temperature	0° F to 220° F (-18° C to 105° C)	
Body Material Type	Alloy Steel, Ductile Iron	
Platings and Coatings	Black Oxide	
Slip Ring Options	Full line of standard electrical slip rings and custom options available. See page 10	
Mounting Options	Tapped holes on the ends of the shaft and housing	

Values are dependent on a combination of all application parameters. Please consult with DSTI.
 High temperature applications may require alternative seal materials. Please consult with DSTI.
 Oil/Hydraulic media must be petroleum-based.
 The rotary union should not be hard mounted on both shaft and housing as misalignment will cause damage.



(4) #8 SAE-ORB (3/4"-16 UNF) Connections

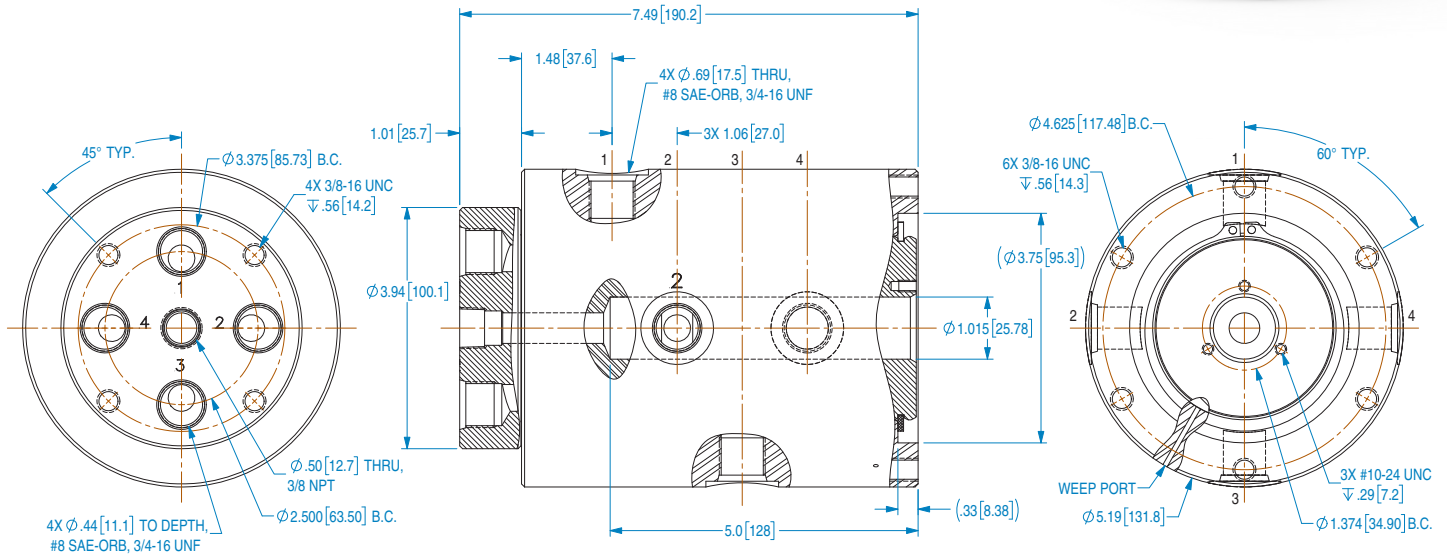

(4) #16 SAE-ORB (1-5/16"-12 UN) Connections

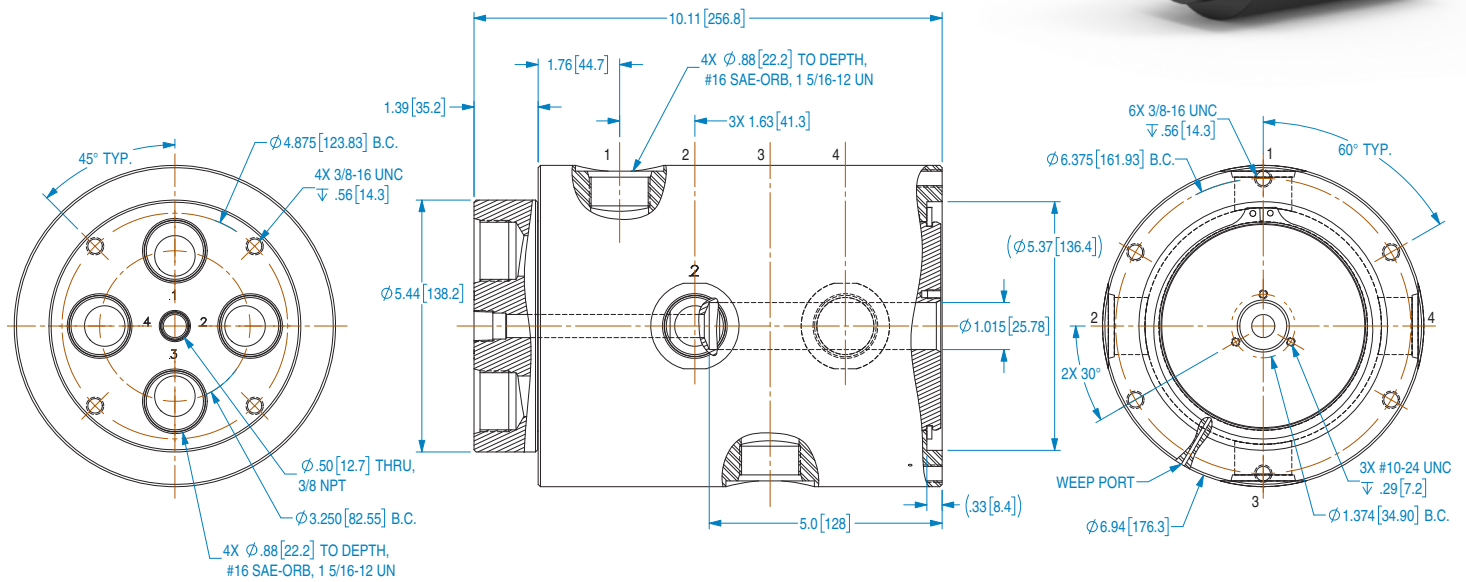



(6) #8 SAE-ORB (3/4"-16 UNF) Connections

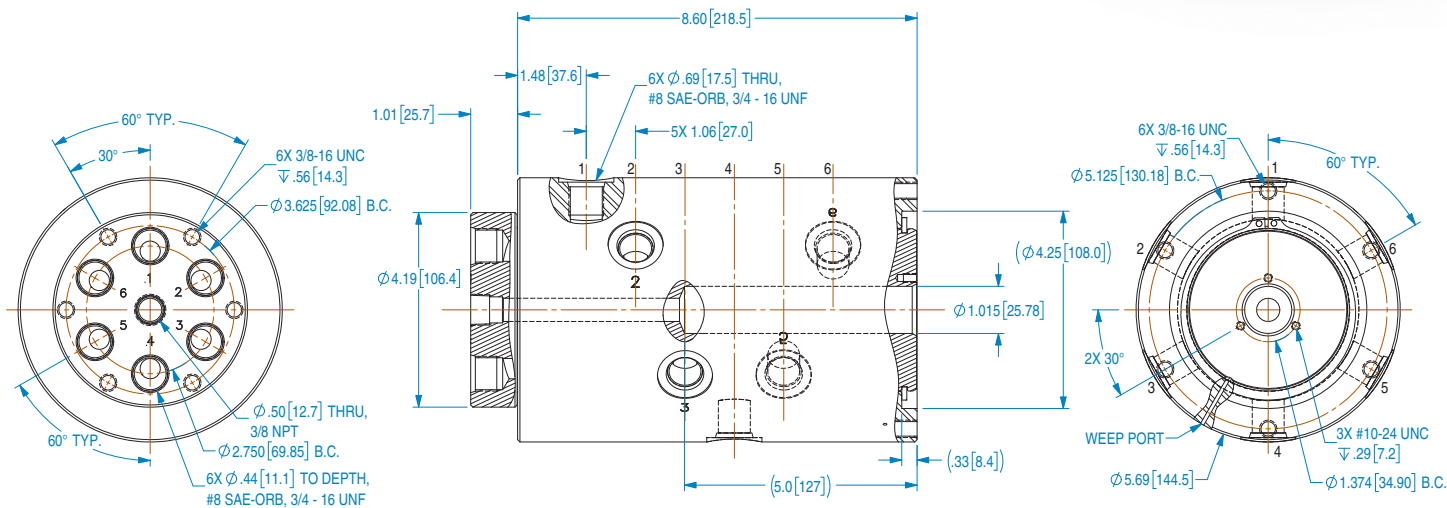

(6) #16 SAE-ORB (1-5/16"-12 UN) Connections

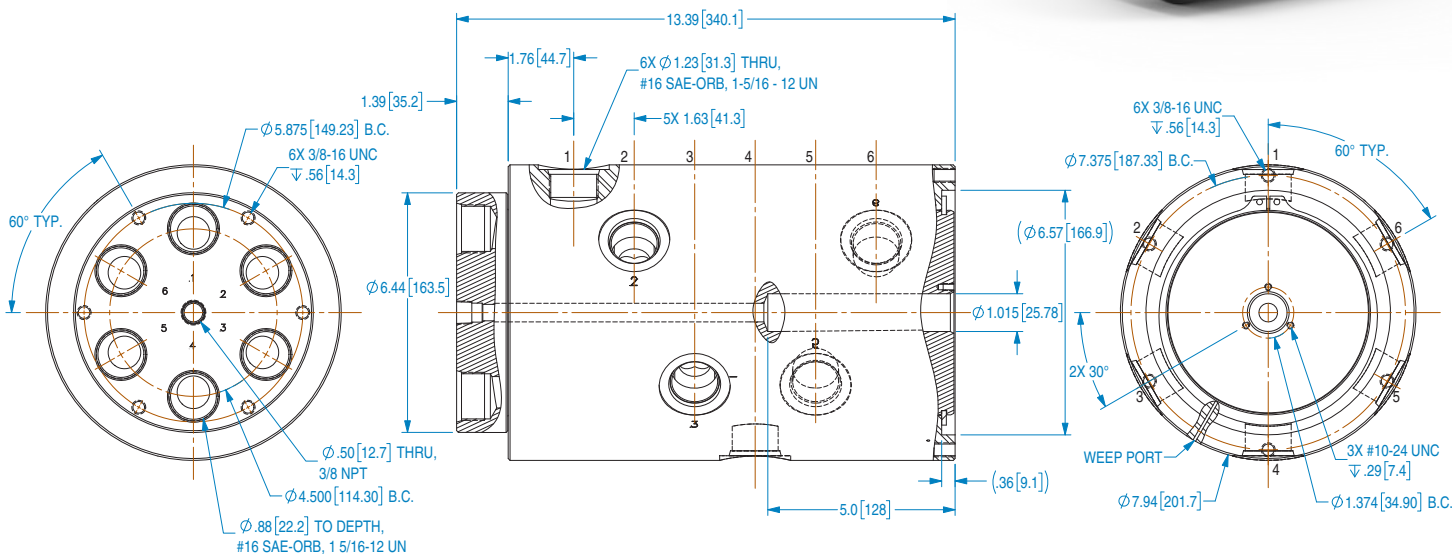



Ethernet Slip Rings Available

100 BaseT & 1000 BaseT Ethernet Connections

High-Quality, Gold-on-Gold Contacts

Capsule & Thru-bore Options

Low Electrical Noise

Analog/Digital Transfer

Nylon Cord Grip Comes Standard

Compatible With a Range of Data Bus Protocols



AVAILABLE SLIP RINGS

PART #	# OF CIRCUITS	MAX AMPS/ CIRCUIT	MAX VOLTS	MAX DATA SPEED
ES6	6	2	240	Under 50 Mbps
ES12 ⁴	12	2	240	Under 50 Mbps
ES18	18	2	240	Under 50 Mbps
ES24 ⁴	24	2	240	Under 50 Mbps
ES36	36	2	240	Under 50 Mbps
ES56 ⁴	56	2	240	Under 50 Mbps
ESE64	10	(6x) 2A	240	100 Mbps
ESE264 ²	12	(2x) 5A, (6x) 2A	240	100 Mbps
ESE224	8	(2x) 10A, (2x) 2A	240	100 Mbps
ESE2124 ²	18	(2x) 5A, (12x) 2A	240	100 Mbps
ESE284	14	(2x) 10A, (8x) 2A	240	100 Mbps
ESE438 ³	51	(43x) 2A	240	1 Gbps
ESE4358	47	(4x) 5A, (35x) 2A	240	1 Gbps
ESE2358 ³	45	(2x) 10A, (35x) 2A	240	1 Gbps
ESE8278	43	(8x) 5A, (27x) 2A	240	1 Gbps
ESE24278 ³	41	(2x) 10A, (4x) 5A, (27x) 2A	240	1 Gbps

PART #	# OF CIRCUITS	MAX AMPS/ CIRCUIT	MAX VOLTS	MAX DATA SPEED
ESM36	9	(3x) 10A, (6x) 2A	240	Under 50 Mbps
ESM312 ⁴	15	(3x) 5A, (12x) 2A	240	Under 50 Mbps
ESM420	24	(4x) 10A, (20x) 2A	240	Under 50 Mbps
ESM428 ⁴	32	(4x) 5A, (28x) 2A	240	Under 50 Mbps
ESM440	44	(4x) 10A, (40x) 2A	240	Under 50 Mbps
ESM448 ⁴	52	(4x) 5A, (48x) 2A	240	Under 50 Mbps
EST6	6	10	600	Under 50 Mbps
EST12 ⁴	12	10	600	Under 50 Mbps
EST18	18	10	600	Under 50 Mbps
EST24 ⁴	24	10	600	Under 50 Mbps
ESET4	4	Ethernet Only	240	100 Mbps
ESET8 ³	8	Ethernet Only	240	1 Gbps
ESET68	14	(6x) 10A	600	1 Gbps
ESET128 ³	20	(12x) 10A	600 ⁵	1 Gbps
ESET184	22	(18x) 10A	600	100 Mbps

All slip ring lead wire lengths are 48" (1219mm)

EST / ESET slip rings are 36" (914mm)

100 BaseT Ethernet connections

1000 BaseT Ethernet connections

In order to successfully transfer digital data signals, a variety of conditions must be met. Please consult with DSTI for approval.

600V max on 16 AWG power circuits, 240v maximum on Ethernet cable.

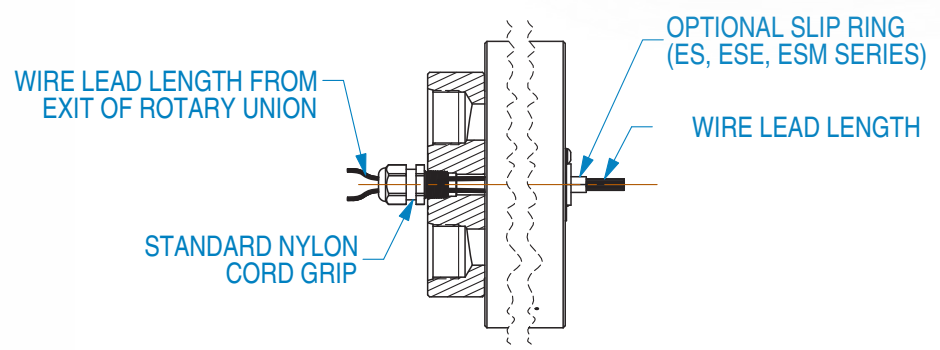
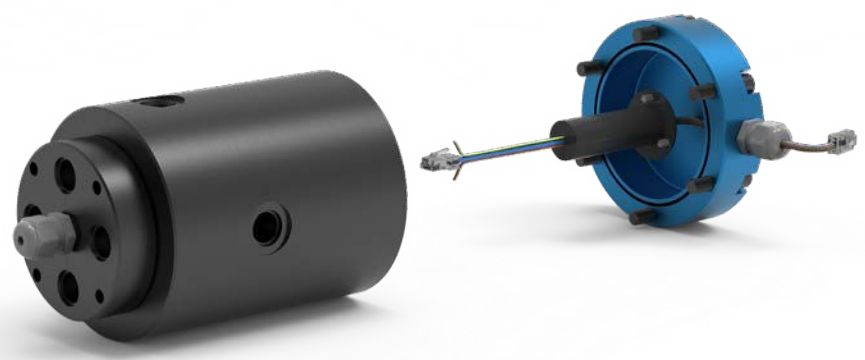

OPTIONAL SLIP RING CAP

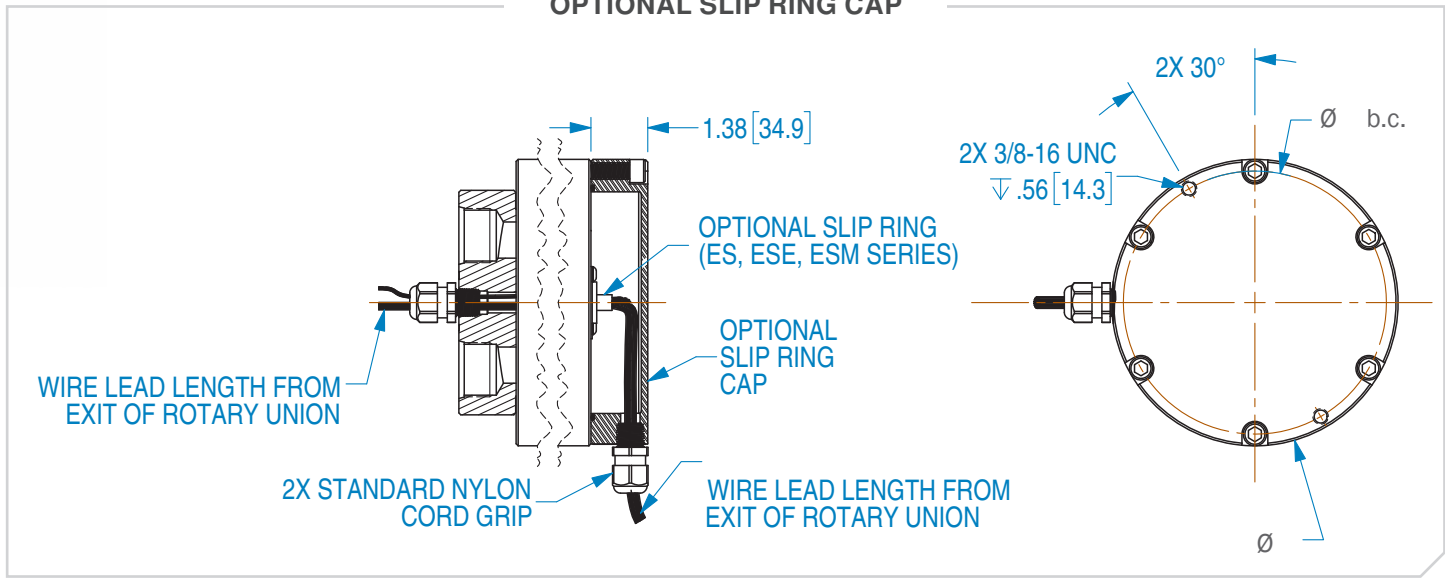

Model					
	42" [1067mm]	48" [1219mm]	44" [1118mm]	4.625" [117.48mm]	5.19" [131.8mm]
HVH-306041	39" [991mm]	48" [1219mm]	43" [1092mm]	6.375" [161.93mm]	6.94" [176.3mm]
	40" [1016mm]	48" [1219mm]	44" [1118mm]	5.125" [130.18mm]	5.69" [144.5mm]
HVH-306061	36" [914mm]	48" [1219mm]	42" [1067mm]	7.375" [187.33mm]	7.94" [201.7mm]

Wire lengths are approximations.

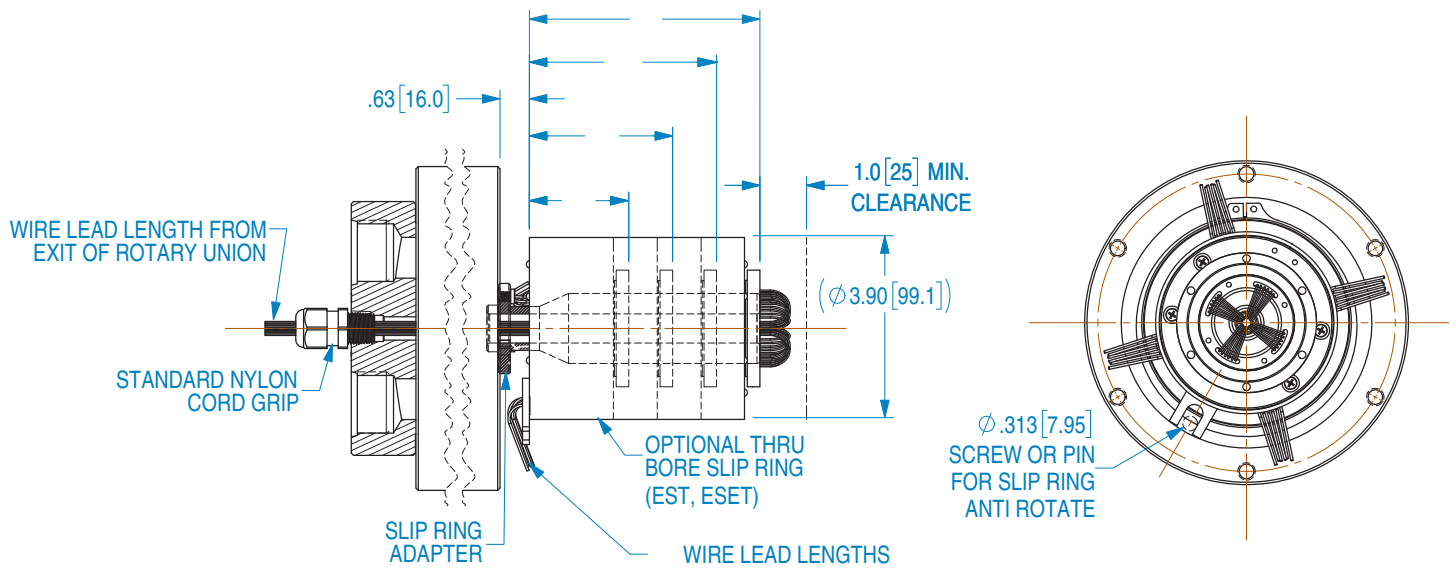
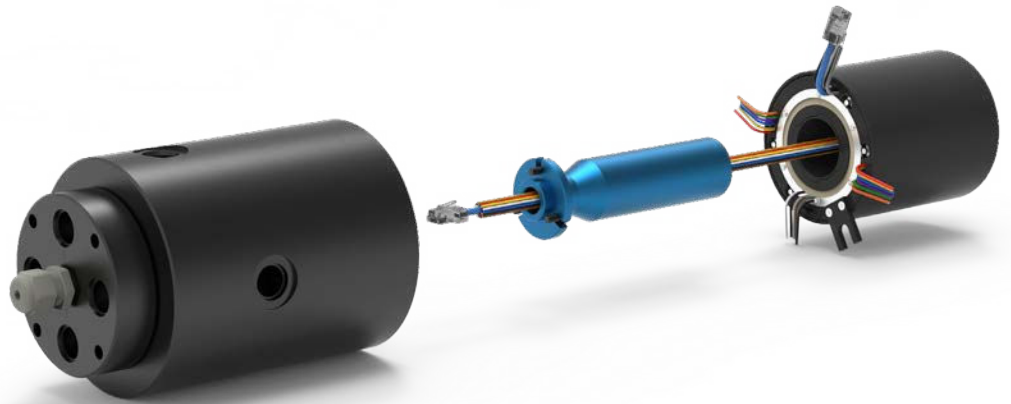

Model		
	22" [559mm]	36" [914mm]
HVH-306041	17" [432mm]	36" [914mm]
	19" [483mm]	36" [914mm]
HVH-306061	15" [381mm]	36" [914mm]

Wire lengths are approximations.

- 4.94" [125.5mm]
- 4.01" [101.9mm]
- 3.07" [78.0mm]
- 2.13" [54.1mm]



PREPARATION:

Remove the rotary union from the shipping container. Inspect the entire assembly, including all passage connections to make sure that they are clean and no visual damage occurred during transport. If the assembly is a rotary union/electrical slip ring, the electrical slip ring may be packaged separately to protect during shipping. If this is the case, mount the electrical slip ring to the rotating union assembly using the supplied hardware.

RECOMMENDED INSTALLATION PRACTICE:

DSTI does not recommend mounting the rotary union with both the shaft & housing components solidly bolted into place. One of the two components should be mounted in a manner that allows for some movement in the event of misalignment or run-out during rotation. Using only the supply lines or hoses to fix the stationary component in place is also not recommended. An anti-rotation arm that attaches to the stationary part of the rotary union assembly and rests against part of the equipment framework is recommended (see figure 1).

MOUNTING A ROTARY UNION W/ AN ELECTRICAL SLIP RING:

Make sure the electrical wiring is fixed in place and protected from contact with other components or equipment. Care should be taken to make sure the slip ring area remains clean and dry during use.

SHAFT MOUNTING, THREADED CONNECTIONS:

Equipment mounting surface needs to be concentric to the center line of the rotary union shaft to assure proper function. Make sure all fittings are properly tightened & pipe thread sealant is used as required.

HOUSING MOUNTING

If using the housing to secure the union into a piece of equipment, bolt the assembly into place using the tapped holes on the back of the housing.

INITIAL START-UP:

After rotary union is installed, a dry run is recommended to assure proper mounting of the rotating union assembly. Begin rotation of the equipment, and verify that while rotating at the maximum operating speed there is no visible movement of the rotary union assembly due to misalignment.

FIGURE 1





DSTI Warrants, for a period of 2 years from the date of original delivery, its products to be free from defects in material and workmanship. DSTI's obligation under this warranty is limited to repair or replacement at its factory of any part or parts of said products which shall be returned to DSTI with transportation charges prepaid and which DSTI's examination shall disclose to its satisfaction to have been defective. Under no circumstances shall DSTI be held liable for loss, damage, cost of repair of consequential damages of any kind in connection with the sale, use or repair of any product purchased from DSTI. Warranty is subject to change.

At DSTI, our product solutions are directly influenced by the industries we serve. If an existing product isn't a perfect fit for our customers' applications, we provide specialized design and manufacturing services to meet the needs of their specifications.

To see examples of our customized solutions, please visit:



PRODUCT DOWNLOADS

For Catalogs, Brochures,
Models and Drawings visit:

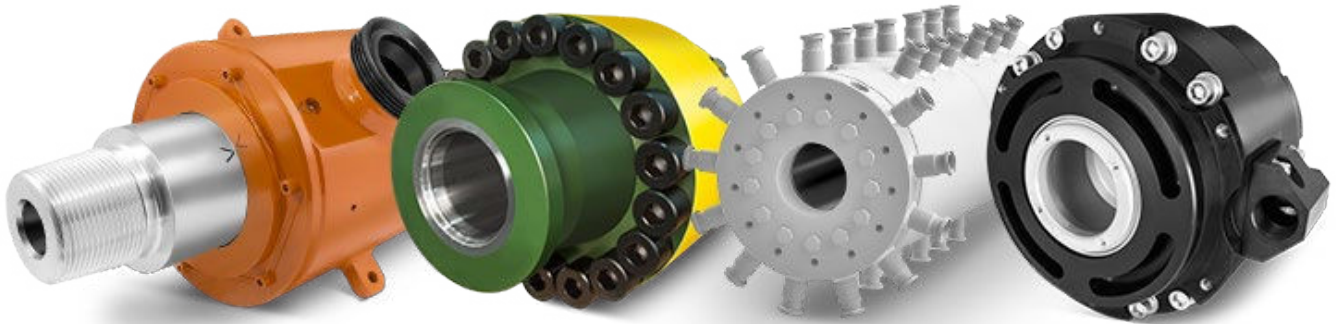

Dynamic Sealing Technologies, Inc

13829 Jay Street NW
Andover, MN 55304
USA

763.786.3785
866.700.3784
www.dsti.com