

FLAT Series

SVTM F

Outrunner Brushless DC Motors

Contents

Model	Ø	Torque	Power	Page
SVTM F 01	20mm	up to 7.8mNm	5W	92
SVTM F 02	32mm	up to 26mNm	8W	93
SVTM F 03	45mm	up to 50mNm	26W	94
SVTM F 03	45mm	up to 84mNm	46W	95
SVTM F 03	45mm	up to 130mNm	66W	96
SVTM F 04	60mm	up to 290mNm	112W	97
SVTM F 05	90mm	up to 457mNm	130W	98
SVTM F 05	90mm	up to 964mNm	169W	99

FLAT
BRUSHLESS

FLAT Series SVTM F

Outrunner Brushless DC Motors



Customizable



Compact



High torque



The natural geometry of the outrunner Brushless Flat Motors, as well as the iron core winding, are the perfect fit for applications requiring high-torque in reduced dimensions.

Simplified design, high-end material selection, and automated manufacturing make the Flat Motors a high-performance solution at a competitive price.

Our vocation in listening to the client's requirements has led us to develop a customization-minded offer, focusing on specific application requirements such as integrated feedbacks, special cables and the geometry of shafts and flanges.

Benefits

High power density

High torque

High efficiency

Cost-effective

Compact

Customizable

Product code

SVTM F ○○ - ◡◡◡◡ - ◊◊ - □ - △◡☆

Series

○ Diameter
 ø20mm [01]; ø32mm [02];
 ø45mm [03]; ø60mm [04];
 ø90mm [05]

◡ Nominal torque

◊ Nominal voltage

□ Shaft
 Single (standard) [S];
 Double [D]*

△ Connection
 Wires with connector (standard on SVTM F 04) or
 flexprint (standard on SVTM F 01, SVTM F 02) [W];
 PCB with connectors (standard on SVTM F 03, SVTM F 05) [C]

◡ Feedback
 Hall sensors (standard) [H];
 Integrated incremental encoder with Hall sensors [E]**

☆ Customization

** Only available for SVTM F 03-0.130, SVTM F 04 and SVTM F 05

Features

Winding	3 phases
Operating temperature	-20° +55° (other temperature ranges on request)
Insulation class	B, 130°C
Magnets	Neodymium
Design technology	Outer rotor

Feedback

Hall Sensor (standard)
Integrated incremental encoder (available on SVTM F 03, SVTM F 04, SVTM F 05)*

Customizations

Integrated feedback
Flange shape
Shaft
Connectors
Wires

* Please contact factory for more details

Table explanation

1 Nominal voltage

It is the applied voltage between two powered phases in block commutation. All nominal data (lines 2 – 9) refer to this voltage. Lower and higher voltages are permissible, provided that limits are not exceeded.

2 No load speed

It is the speed at which the unloaded motor runs with the nominal voltage applied. It is proportional to the applied voltage.

3 No load current

This is the typical current that the unloaded motor draws when operating at nominal voltage. No load friction depends heavily on temperature. It decreases in extended operation and increases at lower temperatures.

4 Nominal speed

It is the speed set for operation at nominal voltage and nominal torque at a motor temperature of 25°C.

5 Nominal torque

It is the torque generated for operation at nominal voltage and nominal current at a motor temperature of 25°C. It is at the limit of the motor's continuous operation range. Higher torques heat up the winding too much.

6 Nominal current

It is the current in the active phase the nominal torque at the given nominal speed (= max. permissible continuous load current). The maximum winding temperature is reached at 25°C ambient temperature in continuous operation with Nominal current.

6 Peak torque

7 Peak current

Stall torque is the linearly calculated load torque for motors that causes the shaft to stall at nominal voltage. This torque often cannot be achieved due to saturation effects.

Stall current is the quotient from nominal voltage and the motor's terminal resistance. Stall current is equivalent to stall torque. With larger motors, Stall current cannot be reached due to the amplifier's current limits.

8 Line to line resistance

It is determined by the resistance at 25 °C between two motor phase.

9 Line to line inductance

It is the winding inductance between two motor phase

10 Terminal inductance

It is the winding inductance between two motor phase.

11 Back EMF constant

It indicates the theoretical no load speed per volt of applied voltage, disregarding friction losses.

12 Speed constant

It indicates the theoretical no load speed per volt of applied voltage, disregarding friction losses.

13 Speed/torque gradient

The speed/torque gradient is an indicator of the motor's performance. It is based on the quotient of ideal no load speed and ideal stall torque (tolerance $\pm 20\%$).

14 Mechanical time constant

It is the time required for the rotor to accelerate from standstill to 63% of its no load speed.

15 Shaft radial play

Radial play is the bearing's radial movement.

16 Shaft axial play

Axial play is the bearing's axial movement. A spring is utilized to preload the motor's bearings.

17 Thermal resistance winding-housing

Characteristic values of thermal contact resistance without additional heat sinking. Lines 17 and 18 combined define the maximum heating at a given power loss (load). Thermal resistance R_{th2} on motors with metal flanges can decrease by up to 80% if the motor is coupled directly to a good heat-conducting.

18 Thermal time constant winding

These are the typical reaction times for a temperature change of winding and motor. It can be seen that the motor reacts much more sluggishly in thermal terms than the winding. The values are calculated from the product of thermal capacity and given heat resistances.

19 Operation ambient

Operating temperature range. This derives from the heat reliability of the materials.

20 Ambient temperature

Operating temperature range. This derives from the heat reliability of the materials.

21 Max. permissible winding temperature

Maximum permissible winding temperature.

22 Max. permissible speed

Is the maximum recommended speed based on thermal and mechanical perspectives. A reduced service life can be expected at higher speeds.

23 Radial play

Radial play is the bearing's radial movement

24 Max. axial load (dynamics)

Dynamic: axial loading permissible in operation. If different values apply for traction and thrust, the smaller value is given.

25 Max force for press fits (static)

Maximum axial force applying to the shaft at standstill if the force is not input at the other shaft end. This is not possible for motors with only one shaft end.

26 Max. radial load

The value is given for a typical distance from the front flange. As the distance increases, this value decreases.

27 Number of pole pairs

Number of north poles of the permanent magnet. The phase streams and commutation signals pass through per revolution p cycles. Servo-controllers require the correct details of the number of pole pairs.

28 Number of phases

All motors have three phases.

29 Weight



Flat Series SVTM F 01

5 Watt

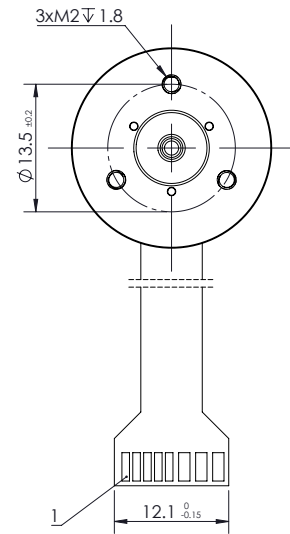
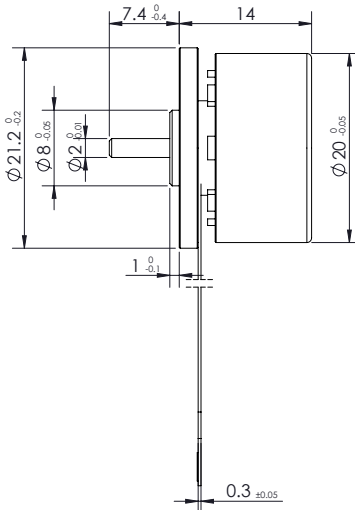
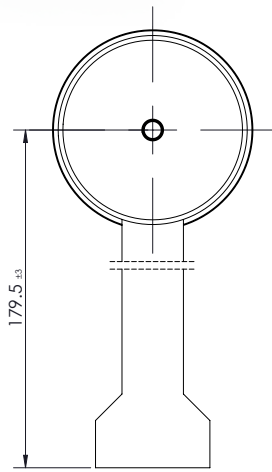

V 3

Flying leads

Mating: MOLEX 52207-1133

PIN1	Vhall (5-24 VDC)
PIN2	Hall sensor HC
PIN3	Hall sensor HA
PIN4	Hall sensor HB
PIN5	GND
PIN6	Motor winding MC
PIN7	Motor winding MB
PIN8	Motor winding MA

Drive combinations

E50 / E40 (Vout 90%) or E55 / E45 (Vout 100%)

Gearbox combinations

Please contact factory for more details

Values	Units	Tolerance	SVTM F 01 12 VDC	24 VDC
Motor data				
1	Nominal voltage	VDC	12	24
2	No load speed	rpm	±10% 9530	9530
3	No load current	mA	23	12
4	Nominal speed	rpm	±10% 5170	5220
5	Nominal torque	mNm	7.59	7.74
6	Nominal current	A	0.63	0.32
7	Peak torque	mNm	19	20
8	Peak current	A	±10% 1.62	0.85
Characteristics				
9	Line to line resistance	ohms@25°C	±10% 7.2	26.1
10	Line to line inductance	mH	±20% 0.62	2.6
11	Torque constant	mNm/A	±10% 12	24
12	Back EMF constant	Vrms/kRPM	±10% 0.89	1.78
13	Rotor inertia	g cm ²		5.1
Mechanical data (preloaded ball bearings)				
14	Max axial-force	N		4.8
15	Max radial-force*	N		14
16	Shaft radial play	mm @4N		0.02
17	Shaft axial play	mm @4N		0.14
Other specifications				
18	Number of poles	#		8
19	Weight	g		23
20	Operation ambient	°C	-20 +50 Humidity max 85% (no condensation)	

*@ 5mm from the flange



Flat Series
SVTM F 02

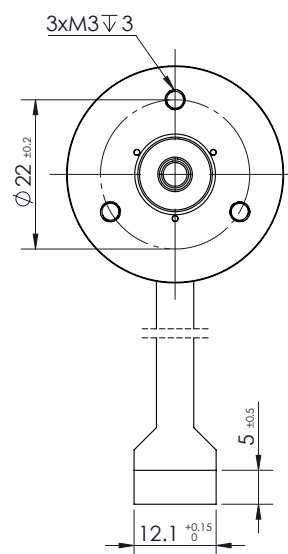
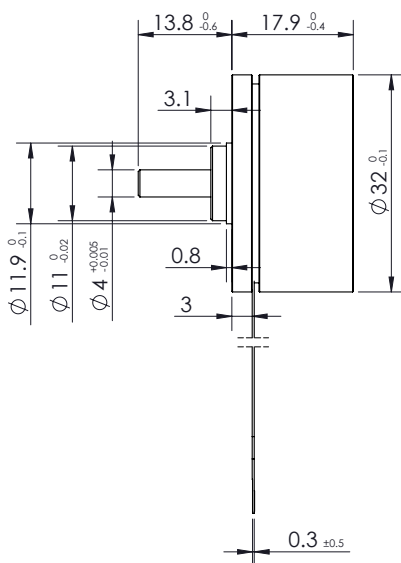
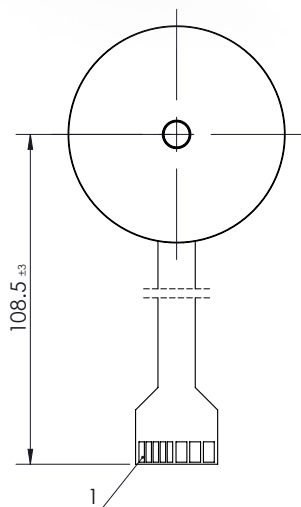

V 3

Flying leads

Mating: MOLEX 52207-1133

PIN1	Vhall (5-24 VDC)
PIN2	Hall sensor HC
PIN3	Hall sensor HA
PIN4	Hall sensor HB
PIN5	GND
PIN6	Motor winding MC
PIN7	Motor winding MB
PIN8	Motor winding MA

Drive combinations

E50 / E40 (Vout 90%) or E55 / E45 (Vout 100%)

Gearbox combinations

Please contact factory for more details

Values	Units	Tolerance	SVTM F 02				
			9 VDC	12 VDC	24 VDC	48 VDC	
Motor data							
1	Nominal voltage	VDC	9	12	24	48	
2	No load speed	rpm	±10%	3750	4650	4530	4800
3	No load current	mA		< 0.3	< 0.37	< 0.37	< 0.37
4	Nominal speed	rpm	±10%	2100	2800	2760	2950
5	Nominal torque	mNm		24.6	25.1	25.5	24.7
6	Nominal current	A		1.07	1	0.37	0.257
7	Peak torque	mNm		73.8	75.3	76.5	74.1
8	Peak current	A	±10%	3.2	3	1.59	0.97
Characteristics							
9	Line to line resistance	ohms@25°C	±10%	3.2	3.2	13.7	53
10	Line to line inductance	mH	±20%	1.20	1.21	4.86	27.8
11	Torque constant	mNm/A	±10%	23	24.67	48.2	96.1
12	Back EMF constant	Vrms/kRPM	±10%	1.7	1.8	3.57	7.1
13	Rotor inertia	g cm ²				35	
Mechanical data (preloaded ball bearings)							
14	Max axial-force	N			4.8		
15	Max radial-force*	N			14		
16	Shaft radial play	mm @4N			0.02		
17	Shaft axial play	mm @4N			0.14		
Other specifications							
18	Number of poles	#			8		
19	Weight	g			50		
20	Operation ambient	°C			-20 +50 Humidity max 85% (no condensation)		

*@ 5mm from the flange



Flat Series SVTM F 03

26 Watt

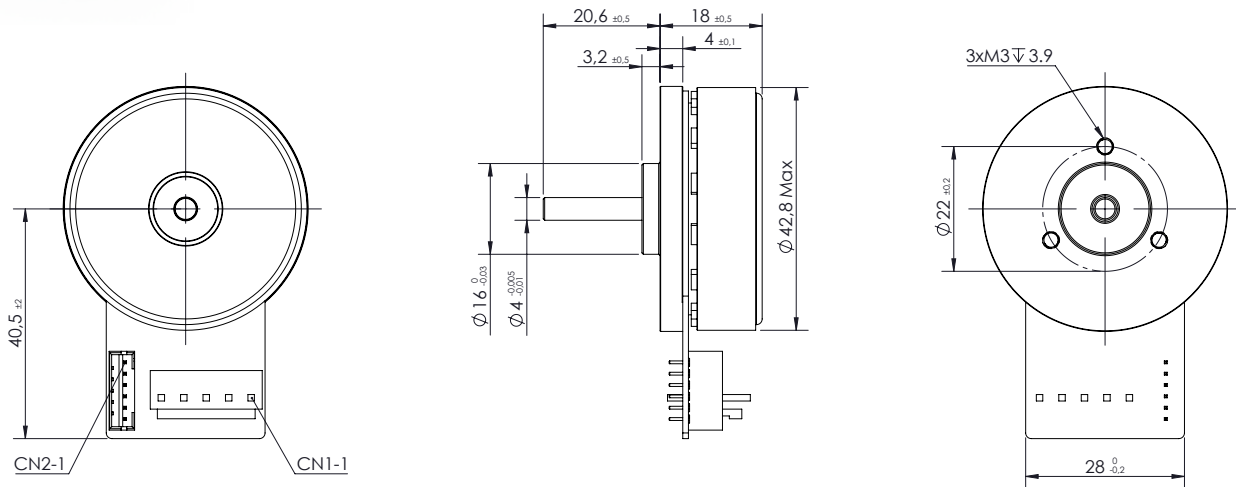
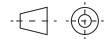

V 3

Connector 1		Connector 2	
JST B5P-VH		JST B6B-PH-K-S	
Mating: JST VHR-5N (power)		Mating: ST PHR-6 (feedback)	
PIN1	GND	PIN1	GND
PIN2	Motor winding MA	PIN2	Vhall (4.5-18VDC)
PIN3	Motor winding MB	PIN3	Hall sensor HC
PIN4	Motor winding MC	PIN4	Hall sensor HA
PIN5	GND	PIN5	Hall sensor HB
		PIN6	GND

Drive combinations
E50 / E40 (Vout 90%) or E55 / E45 (Vout 100%)

Gearbox combinations
Please contact factory for more details

Values	Units	Tolerance	SVTM F 03-0.050 24 VDC
Motor data			
1	Nominal voltage	VDC	24
2	No load speed	rpm	±10% 6500
3	No load current	mA	< 0.3
4	Nominal speed	rpm	±10% 5000
5	Nominal torque	mNm	50
6	Nominal current	A	1.58
7	Peak torque	mNm	150
8	Peak current	A	±10% 4.8
Characteristics			
9	Line to line resistance	ohms@25°C	±10% 1.47
10	Line to line inductance	mH	±20% 0.61
11	Torque constant	mNm/A	±10% 35.5
12	Back EMF constant	Vrms/kRPM	±10% 2.61
13	Rotor inertia	g cm ²	99
Mechanical data (preloaded ball bearings)			
14	Max axial-force	N	10
15	Max radial-force*	N	28
16	Shaft radial play	mm @4N	0.02
17	Shaft axial play	mm @4N	0.14
Other specifications			
18	Number of poles	#	16
19	Weight	g	80
20	Operation ambient	°C	-25 +55 Humidity max 85% (no condensation)

*@ 5mm from the flange



Flat Series
SVTM F 03

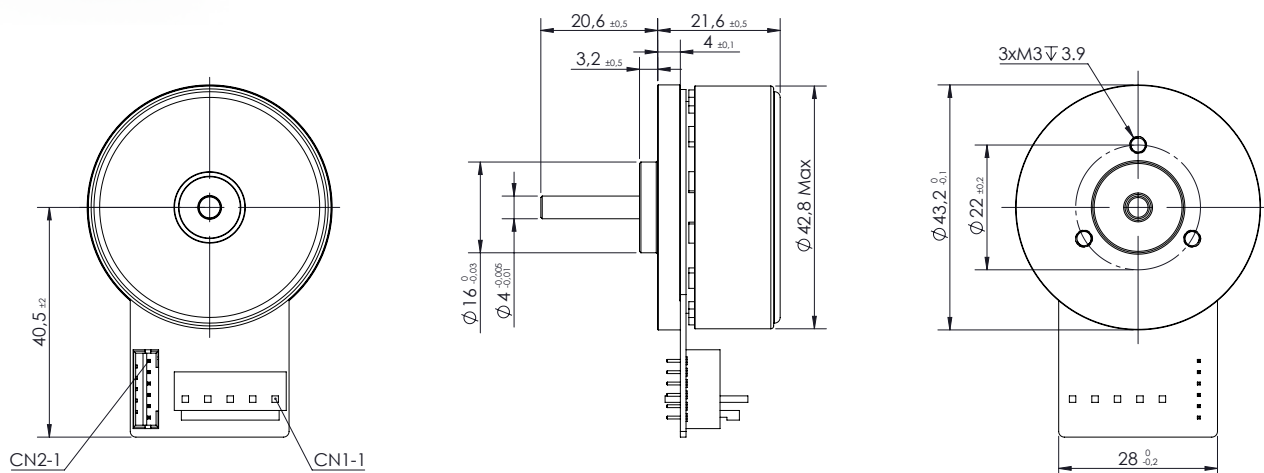

V 3

Connector 1		Connector 2	
JST B5P-VH		JST B6B-PH-K-S	
Mating: JST VHR-5N (power)		Mating: ST PHR-6 (feedback)	
PIN1	GND	PIN1	GND
PIN2	Motor winding MA	PIN2	Vhall (4.5-18VDC)
PIN3	Motor winding MB	PIN3	Hall sensor HA
PIN4	Motor winding MC	PIN4	Hall sensor HC
PIN5	GND	PIN5	Hall sensor HB
		PIN6	GND

Drive combinations
E50 / E40 (Vout 90%) or E55 / E45 (Vout 100%)

Gearbox combinations
Please contact factory for more details

Values	Units	Tolerance	SVTM F 03-0.084 24 VDC
Motor data			
1	Nominal voltage	VDC	24
2	No load speed	rpm	±10% 6700
3	No load current	mA	< 0.4
4	Nominal speed	rpm	±10% 5260
5	Nominal torque	mNm	84
6	Nominal current	A	2.36
7	Peak torque	mNm	250
8	Peak current	A	±10% 7
Characteristics			
9	Line to line resistance	ohms@25°C	±10% 0.7
10	Line to line inductance	mH	±20% 0.33
11	Torque constant	mNm/A	±10% 33.5
12	Back EMF constant	Vrms/kRPM	±10% 2.53
13	Rotor inertia	g cm ²	135
Mechanical data (preloaded ball bearings)			
14	Max axial-force	N	10
15	Max radial-force*	N	28
16	Shaft radial play	mm @4N	0.02
17	Shaft axial play	mm @4N	0.14
Other specifications			
18	Number of poles	#	16
19	Weight	g	120
20	Operation ambient	°C	-25 +55 Humidity max 85% (no condensation)

*@ 5mm from the flange



Flat Series SVTM F 03

66 Watt

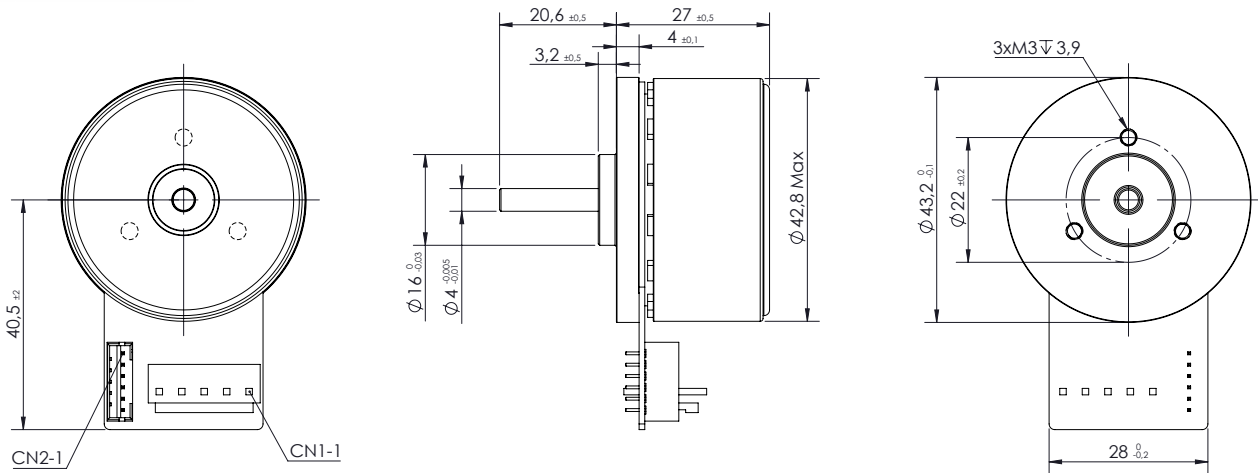

V 3

Connector 1		Connector 2	
JST B5P-VH		JST B6B-PH-K-S	
Mating: JST VHR-5N (power)		Mating: ST PHR-6 (feedback)	
PIN1	GND	PIN1	GND
PIN2	Motor winding MA	PIN2	Vhall (4.5-18VDC)
PIN3	Motor winding MB	PIN3	Hall sensor HA
PIN4	Motor winding MC	PIN4	Hall sensor HC
PIN5	GND	PIN5	Hall sensor HB
		PIN6	GND

Drive combinations	
E50 / E40 (Vout 90%) or E55 / E45 (Vout 100%)	
Optional encoder	
Integrated incremental encoder with Hall sensors	
Resolution	1024ppr, TTL
Channels	A,A/,B,B/
Length increase	+2mm
Please contact factory for more details	
Gearbox combinations	
Please contact factory for more details	

Values	Units	Tolerance	SVTM F 03-0130 24 VDC
Motor data			
1	Nominal voltage	VDC	24
2	No load speed	rpm	±10% 6100
3	No load current	mA	< 0.5
4	Nominal speed	rpm	±10% 4840
5	Nominal torque	mNm	130
6	Nominal current	A	3.26
7	Peak torque	mNm	390
8	Peak current	A	±10% 9.5
Characteristics			
9	Line to line resistance	ohms@25°C	±10% 0.56
10	Line to line inductance	mH	±20% 0.27
11	Torque constant	mNm/A	±10% 36.9
12	Back EMF constant	Vrms/kRPM	±10% 2.75
13	Rotor inertia	g cm ²	181
Mechanical data (preloaded ball bearings)			
14	Max axial-force	N	10
15	Max radial-force*	N	28
16	Shaft radial play	mm @4N	0.02
17	Shaft axial play	mm @4N	0.14
Other specifications			
18	Number of poles	#	16
19	Weight	g	150
20	Operation ambient	°C	-25 +55 Humidity max 85% (no condensation)

*@ 5mm from the flange



Flat Series
SVTM F 04

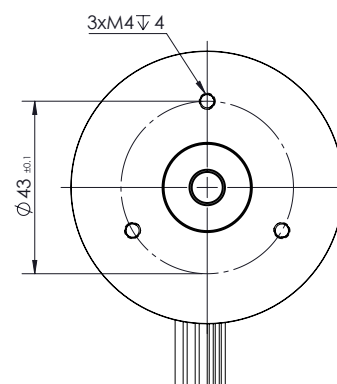
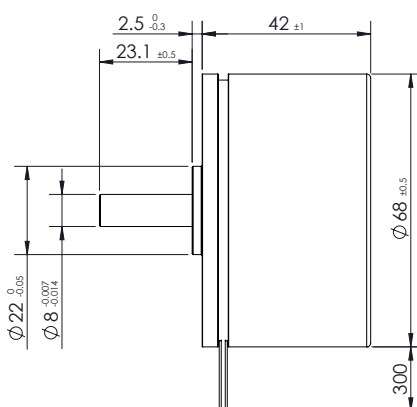
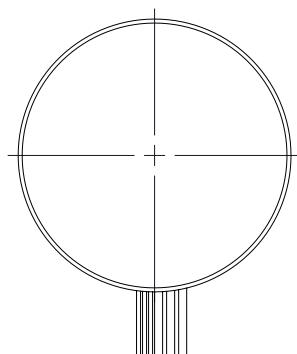

V 3

Flying leads		
AWG26	Red	Vhall (5 VDC)
AWG26	Green	Hall sensor HB
AWG26	Blue	Hall sensor HA
AWG26	White	Hall sensor HC
AWG26	Black	GND
AWG18	Yellow	Motor winding MA
AWG18	Red	Motor winding MB
AWG18	Black	Motor winding MC

Drive combinations	
E50 / E40 (Vout 90%) or E55 / E45 (Vout 100%)	
Optional encoder	
Integrated incremental encoder with Hall sensors	
Resolution	4096ppr, TTL
Channels	A,A/,B,B/,I,I/
Please contact factory for more details	
Gearbox combinations	
Please contact factory for more details	

Values	Units	Tolerance	SVTM F 04 24 VDC
Motor data			
1	Nominal voltage	VDC	24
2	No load speed	rpm	±10% 4400
3	No load current	mA	0.65
4	Nominal speed	rpm	±10% 3700
5	Nominal torque	mNm	290
6	Nominal current	A	5.6
7	Peak torque	mNm	870
8	Peak current	A	±10% 17
Characteristics			
9	Line to line resistance	ohms@25°C	±10% 0.25
10	Line to line inductance	mH	±20% 0.2
11	Torque constant	mNm/A	±10% 54
12	Back EMF constant	Vrms/kRPM	±10% 4.0
13	Rotor inertia	g cm ²	1000
Mechanical data (preloaded ball bearings)			
14	Max axial-force	N	10
15	Max radial-force*	N	28
16	Shaft radial play	mm @4N	0.02
17	Shaft axial play	mm @4N	0.08
Other specifications			
18	Number of poles	#	14
19	Weight	g	500
20	Operation ambient	°C	-25 +55 Humidity max 85% (no condensation)

*@ 10mm from the flange



Flat Series SVTM F 05

130 Watt

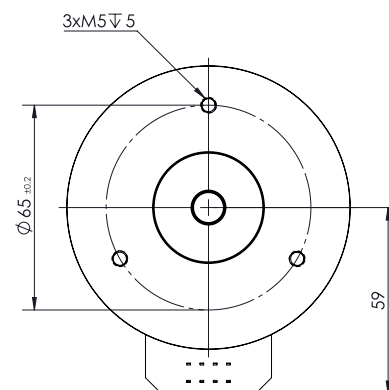
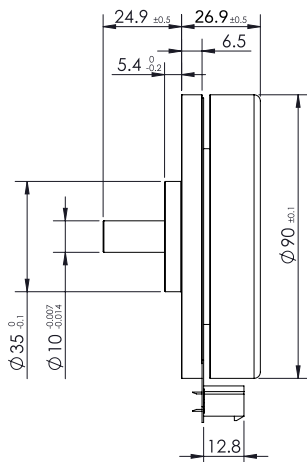
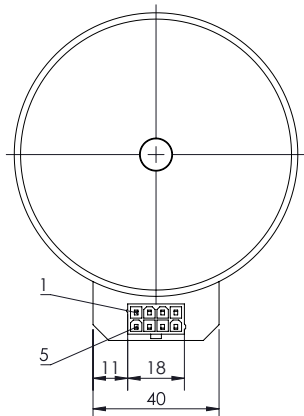

V 3

Connector

MOLEX 39-28-1083

Mating: Molex 039012080

PIN1	Hall sensor HA
PIN2	Hall sensor HB
PIN3	Vhall (5-24 VDC)
PIN4	Motor winding MC
PIN5	Hall sensor HC
PIN6	GND
PIN7	Motor winding MA
PIN8	Motor winding MB

Drive combinations

E50 / E40 (Vout 90%) or E55 / E45 (Vout 100%)

Gearbox combinations

Please contact factory for more details

Values	Units	Tolerance	SVTM F 05-0.457 24 VDC
Motor data			
1	Nominal voltage	VDC	24
2	No load speed	rpm	±10% 3300
3	No load current	mA	0.7
4	Nominal speed	rpm	±10% 2700
5	Nominal torque	mNm	457
6	Nominal current	A	6.8
7	Peak torque	mNm	1600
8	Peak current	A	±10% 23
Characteristics			
9	Line to line resistance	ohms@20°C	±10% 0.21
10	Line to line inductance	mH	±20% 0.19
11	Torque constant	mNm/A	±10% 63
12	Back EMF constant	Vrms/kRPM	±10% 5.2
13	Rotor inertia	g cm ²	3000
Mechanical data (preloaded ball bearings)			
14	Max axial-force	N	45
15	Max radial-force*	N	110
16	Shaft radial play	mm @4N	0.02
17	Shaft axial play	mm @4N	0.08
18	Length (L)	mm	26.9±05
Other specifications			
19	Number of poles	#	24.9
20	Weight	g	600
21	Operation ambient	°C	-25 +55 Humidity max 85% (no condensation)

*@ 10mm from the flange



Flat Series
SVTM F 05

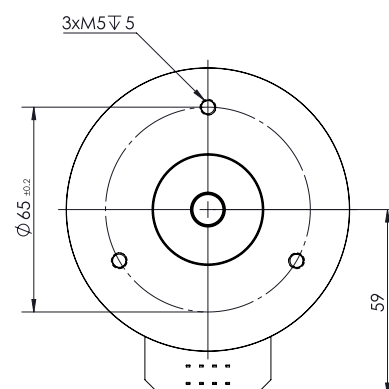
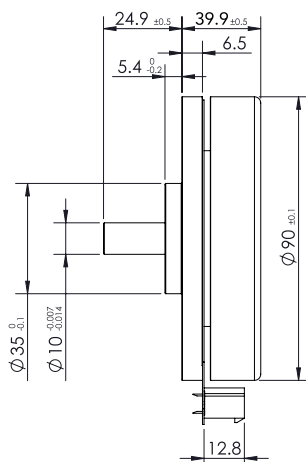
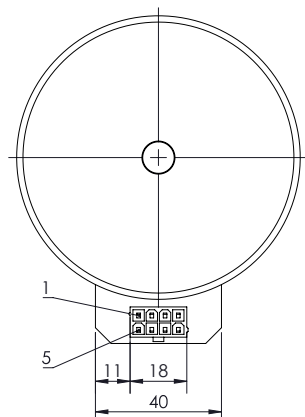

Connector	
MOLEX 39-28-1083	
Mating: Molex 039012080	
PIN1	Hall sensor HA
PIN2	Hall sensor HB
PIN3	Vhall (5-24 VDC)
PIN4	Motor winding MC
PIN5	Hall sensor HC
PIN6	GND
PIN7	Motor winding MA
PIN8	Motor winding MB

Drive combinations	
E50 / E40 (Vout 90%) or E55 / E45 (Vout 100%)	
Optional encoder	
Integrated incremental encoder with Hall sensors	
Resolution	4096ppr, TTL
Channels	A,A/,B,B/,I,I/
Length increase	+2mm
Please contact factory for more details	
Gearbox combinations	
Please contact factory for more details	

Values	Units	Tolerance	SVTM F 05-0.964 48 VDC
Motor data			
1	Nominal voltage	VDC	48
2	No load speed	rpm	±10% 1900
3	No load current	mA	0.35
4	Nominal speed	rpm	±10% 1670
5	Nominal torque	mNm	964
6	Nominal current	A	4.3
7	Peak torque	mNm	3000
8	Peak current	A	±10% 13
Characteristics			
9	Line to line resistance	ohms@20°C	±10% 0.6
10	Line to line inductance	mH	±20% 0.7
11	Torque constant	mNm/A	±10% 241
12	Back EMF constant	Vrms/kRPM	±10% 17.9
13	Rotor inertia	g cm ²	5000
Mechanical data (preloaded ball bearings)			
14	Max axial-force	N	45
15	Max radial-force*	N	110
16	Shaft radial play	mm @4N	0.02
17	Shaft axial play	mm @4N	0.08
18	Length (L)	mm	39.9±05
Other specifications			
19	Number of poles	#	39.9
20	Weight	g	1000
21	Operation ambient	°C	-25 +55 Humidity max 85% (no condensation)

*@ 10mm from the flange